

# SECTION 1

## SMART PAYOUT MANUAL SET

### QUICK START AND CONFIGURATION GUIDE

INTELLIGENCE IN VALIDATION

Innovative Technology assume no responsibility for errors, omissions, or damages resulting from the use of information contained within this manual.



SaXXot Deutschland GmbH, Zeppelinstrasse 73, DE 81669 München  
Tel.: +49 (0)894141446-00 Fax: +49 (089) 4141446-75, [info@saxxot.de](mailto:info@saxxot.de) - [www.saxxot.de](http://www.saxxot.de)

**SMART PAYOUT MANUAL SET – SECTION 1**

1.	QUICK START AND CONFIGURATION GUIDE	3
1.1	Assembly	3
1.2	Panel Layout	7
1.3	Earth Bonding	7
1.4	DIP Switch Settings	8
1.5	Connectors and Pinouts	8
1.6	Status Indicators	9
1.7	Programming	9
1.8	Technical Specifications	9
1.9	SMART Payout Flash Codes	10
1.10	NV200 Bezel Flash Codes	11
1.11	Fault Finding	12
1.12	Frequently Asked Questions	13



## 1. QUICK START AND CONFIGURATION GUIDE

This section is one part of a complete manual set: most users should use this section of the manual - typical users are software engineers looking at how to make it work, project engineers evaluating their first unit, or installation engineers installing the unit into a host machine.

This section contains the essential information that a user needs to quickly assemble and configure the SMART Payout unit ready for installation into the host machine.

### 1.1 Assembly

The payout module is designed to be fitted to the Innovative Technology NV200 bank note validator. Connecting the payout module to an NV200 validator is a simple operation, described in the steps outlined here:

1. Remove the NV200 cash box from the metal chassis
2. If installing into a host machine, the NV200 chassis is then mounted by using the tapped holes on either side of the chassis using 4 x M4 fixing screws and a suitable mounting bracket



#### Information

Check fixing screw length before final installation to avoid damage to the cash box.

The length of the fixing screws fitted to either side of the chassis must be no longer than 6 mm plus the thickness of the mounting bracket.



3. Unlock the NV200 cashbox and head release lock (if fitted)
4. Lift the silver head release catch located on the front of the NV200
5. Slide the head unit forward and lift up



6. Mount the payout module using the mounting brackets on the rear of the NV200 chassis
7. Replace the NV200 head unit taking care that the connectors on the payout module line up with the connectors on the rear of the NV200



8. Ensure the NV200 head unit is securely in place – check that the release catch is fully down

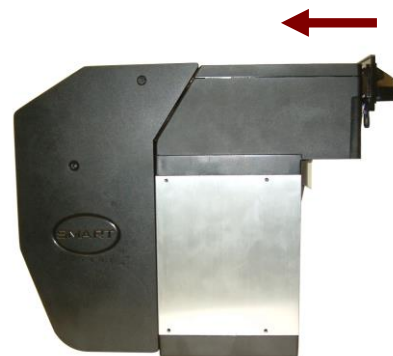

### Information

Payout module removal.

The payout module cannot be removed until the head unit has been slid forwards.

## Bezel Removal and Replacement

**WARNING!**  
Ensure bezel is secured to validator

The front bezel should be secured to the validator head using screws if the SMART Payout unit is being installed and transported inside a host machine.

**Information**  
Check bezel fixing screw length before installation.

The length of the bezel fixing screws must be no more than 12 mm in length.

The bezel on the front of the validator head has been designed to be removed and refitted very easily.

To remove or refit the bezel the top cover must be open fully to allow access to the bezel mounting area.

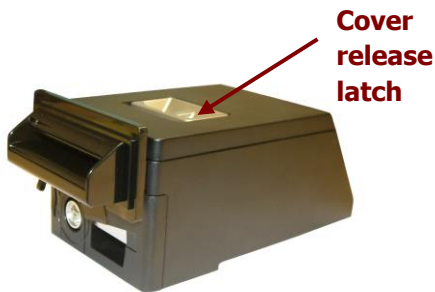

**Validator note path cover**

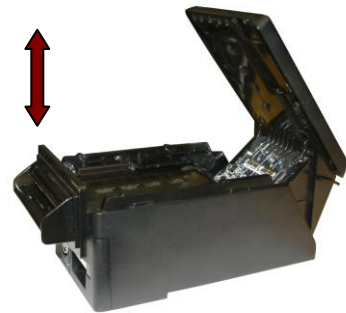

**Bezel removal and fitting**

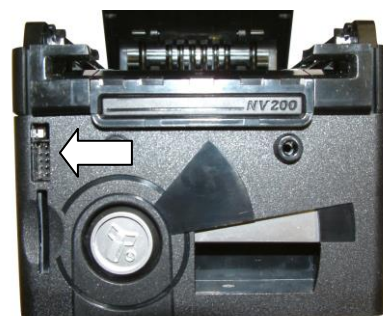
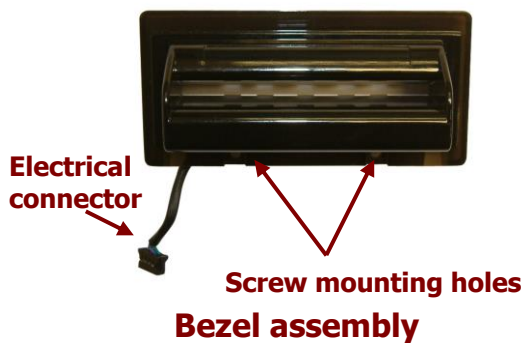

**Bezel connector socket**



Removing the bezel: Lift the upper cover by pulling the top latch forward. If fitted, remove the two bezel securing screws and then slide the bezel assembly upwards. Finally unplug the cable from the socket on the front of the validator head.

Fitting the bezel: Lift the upper cover by pulling the latch forward. Connect the cable from the bezel assembly to the socket located on the front of the validator head and slide the assembly down into place and then close the note path upper cover. If required, the bezel can be secured in place with two M3 screws - these are fitted in the two holes at the bottom of the bezel.



## 1.2 Panel Layout

All the connectors and switches needed to set up and interface the SMART Payout unit are easily accessible on the back of the unit:

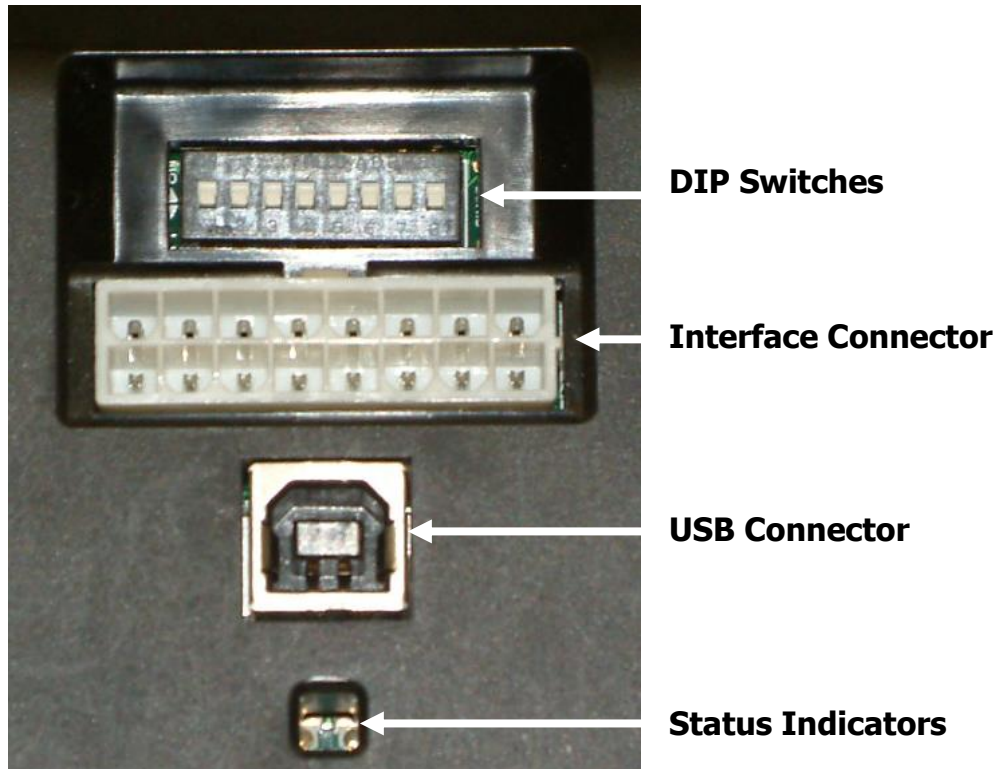

## 1.3 Earth Bonding

It is **very** important that the cashbox chassis is bonded to earth, as lack of proper bonding can cause communication issues and failures with the SMART Payout unit.

The earth bond should be made to any of the 8 holes in the side of the cashbox and be bonded to mains earth, typically through the Power Supply Unit.



### Information

Earth resistance.

The resistance between the cashbox and the Earth pin on the mains plug should be less than 0.7 ohms.

### 1.4 DIP Switch Settings

The SMART Payout unit has a Dual Inline Package (DIP) switch bank that is used to set the various options for the unit. A summary of the switch options are shown below:

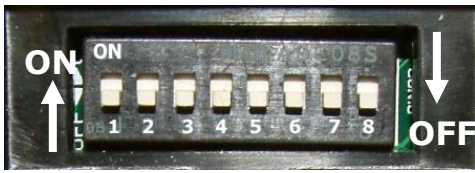

Switch	Option	Default Setting
1	Not Used	OFF
2	Not Used	OFF
3	Not Used	OFF
4	Not Used	OFF
5	Not Used	OFF
6	Not Used	OFF
7	Stop update from NV200	OFF
8	Force diverter to close (unit must be powered up)	OFF

### 1.5 Connectors and Pinouts

The SMART Payout unit has two connectors that are used to allow interfacing and programming.

**i Information**

Power always required regardless of connection type.

Power is always required on pins 1 and 9 of the 16 way connector.

The first connector is a 16 pin socket used to interface the SMART Payout unit to the host machine. The pin numbering of the socket is shown below, as well as an overview of the socket connections:



Pin	Description
1	0V / Ground Connection
9	+12V DC
14	Serial Data In (Rx)
16	Serial Data Out (Tx)

The USB connector is a standard Type B USB socket. The USB socket can be used for programming the SMART Hopper unit and also bench testing – a USB 2.0 compliant Type 'A' to 'B' lead can be used to do this. USB cables should be electrically shielded and less than 5 metres long. **Please note:** Direct USB should **NOT** be used for Host communications. If USB is required than our IF17 (TTL to USB) should be used.





## 1.6 Status Indicators

The SMART Payout unit has two Light Emitting Diode (LED) indicators that are used to show the status of the unit (one Red, one Green) – these can be found on the back of the unit, below the USB connector. If the SMART Payout unit is operating normally, only the Green LED should be lit: when operating normally this LED will flash once every second.

If there is a fault or other issue with the unit, the LEDs will flash as described in subsection 1.9.

## 1.7 Programming

Full details on programming the SMART Payout unit can be found in Section 3 of this manual set (ITL Software Support Guide).

## 1.8 Technical Specifications

The full technical specifications for the SMART Payout unit can be found in Section 6, Appendix B of this manual set. A brief summary is given here:





<b>DC Voltage</b>	<b>Minimum</b>	<b>Nominal</b>	<b>Maximum</b>
Absolute limits	10.8 V	12 V	13.2 V
Supply ripple voltage	0 V	0V	0.25 V @ 100 Hz
<b>Supply Current (when connected to an NV200):</b>			
Standby			400 mA
Running			3 A
Peak (motor stall)			5 A

<b>Interface Logic Levels</b>	<b>Logic Low</b>	<b>Logic High</b>
Inputs	0 V to 0.5 V	+3.7 V to +12 V
Outputs (2.2 k $\Omega$ pull-up)	0.6 V	Pull-up voltage of host interface
Maximum current sink		50 mA per output

We recommend that your power supply is capable of supplying 12V DC at 6.3 A.

## 1.9 SMART Payout Flash Codes

The SMART Payout unit has an inbuilt fault detection facility. If there is a configuration or other error, the Status Indicator LEDs will flash in a particular sequence; a summary of the Flash Codes for the SMART Payout unit is shown below:

Status Indicators		Flashes	Indicated Error	Comments
Red	Green			
		0	No LEDs lit	No power
		1	Motor / barcode error	Check tape in window
		2	Note sensor error	
		3	EEPROM error	Reprogram unit (see Section 3 of this manual set)
		4	Payout jammed	Remove trapped note (see Section 4 of this manual set)
		5	Diverter error	Switch DIP switch 8 on and off
		0	Both LEDs on (no flash)	Turn power on and off
		1	Power reset	For information only
		2	Wakeup from low power	For information only
		3	Software reset	For information only
		4	Software command	For information only
		5	User manual reset	For information only
		6	Power supply issue	Check power supply
		7	Unknown cause	For information only
		1 every second	None	All OK

### 1.10 NV200 Bezel Flash Codes

When the payout module is installed on an NV200 bank note validator additional fault finding help is available, as the NV200 has its own set of Flash Codes. These are displayed in the front bezel of the validator.

A summary of the Bezel Flash Codes for the NV200 is shown below:

Flashes		Indicated Error	Comments
Red	Blue		
<b>0</b>	<b>0</b>	None	
<b>1</b>	<b>1</b>	Note path open	Close note path
	<b>2</b>	Note path jam	Remove obstruction and follow the cleaning procedure in Section 2 of this manual set
	<b>3</b>	Unit not initialised	Contact ITL technical support
<b>2</b>	<b>1</b>	Cashbox removed	Refit cashbox
	<b>2</b>	Cashbox jam	Remove trapped notes
<b>3</b>	<b>1</b>	Firmware checksum error	Download new firmware
	<b>2</b>	Interface checksum error	
	<b>3</b>	EEPROM checksum error	Download new firmware
	<b>4</b>	Dataset checksum error	
<b>4</b>	<b>1</b>	Power supply too low	Check power supply
	<b>2</b>	Power supply too high	
	<b>3</b>	Card format	Reprogram programming card
	<b>4</b>	Payout reset	Turn power on and off
<b>5</b>	<b>1</b>	Firmware mismatch	Reprogram unit

### 1.11 Fault Finding

Please use this flow chart with the Flash Codes in the previous sub-sections as an aid to help resolve any configuration or start up problems you might have after installing the SMART Payout unit.

If you are unsure about the cause or how to resolve the problem, please contact ITL's technical support department.

Support contact details can be found on the ITL website ([www.innovative-technology.co.uk](http://www.innovative-technology.co.uk)), or on the last page of this section.

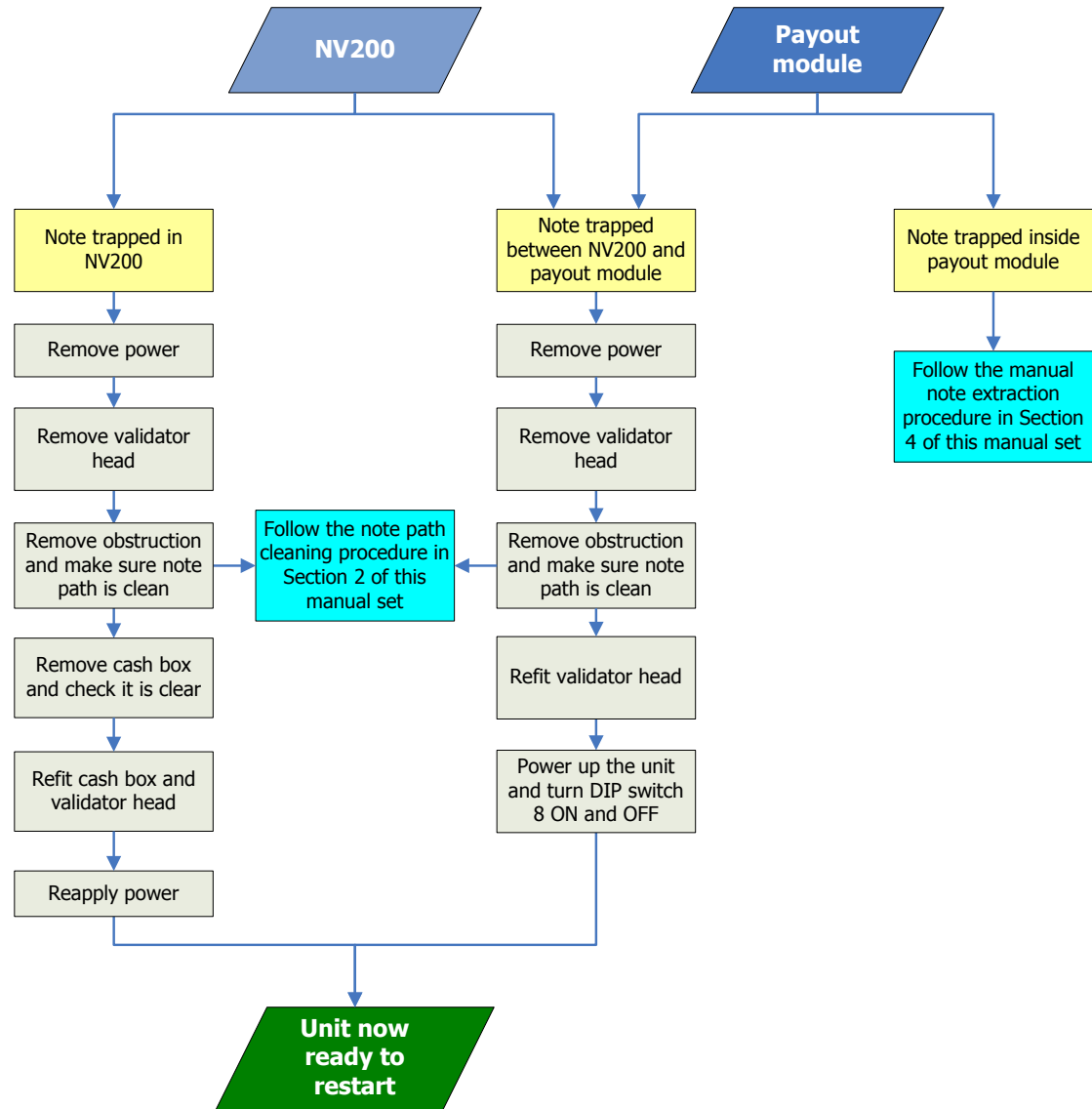

## 1.12 Frequently Asked Questions

a. What settings should I use on the DIP switches on the rear of the unit?

- Look at the DIP switch tables in subsection 1.4

b. The payout unit does not securely lock on the back of the NV200

- Make sure the plastic mountings are fitted on the back of the cashbox.
- Ensure the payout module is correctly located on the mountings before the validator head is installed.

c. My notes are always stacked in the cashbox even though I have chosen for them to go into the payout module.

- Check that the Green LED on the rear of the SMART Payout unit is flashing – see the Flash Codes in subsection 1.9 if this is not the case.
- Make sure the diverter is in the correct position – with the unit powered up, turn DIP switch 8 ON and OFF to make sure (check the information in Section 2, subsection 2.2 of this manual set if you are unsure).
- The Payout module might be disabled in software - send an enable payout command.
- The Payout module might be full – check how many notes are stored using your host software.
- The notes might be detected as damaged or not straight – in this case they will be stacked in the cash box so that they will not jam the payout module.